



ILLINOIS DEPARTMENT OF NATURAL RESOURCES

Office of Oil and Gas Resource Management
One Natural Resources Way Springfield, Illinois 62702-1271



HIGH VOLUME HORIZONTAL HYDRAULIC FRACTURING PERMIT APPLICATION HVHFF-10

References to "1-xx" or "§1-xx" are to the Hydraulic Fracturing Regulatory Act., 225 ILCS 732/1-1 et seq. References to "240.xxx" and "245.xxx" are to 62 Ill. Admin. Code 240 and 245, respectively.

Attachment: HydraulicFracturingFluidsandFlowbackPlan

Please save attachment using the name above

Hydraulic Fracturing Fluids and Flowback Plan §1-35(b)(11); 245.210(a)(11), 245.530, 245.560.

Please review the above-listed statute and rules and describe the handling, storage, transportation and disposal, and recycling or reuse of hydraulic fracturing fluids and flowback in sufficient detail to demonstrate that your plan for these materials meets the requirements of the statute and rules. In so doing, (a) identify, including name, identification number, and specific location, the Class II injection well or wells to be used for disposal, reuse, or facility or facilities to be used for recycling of the fluid; (b) explain the injection schedule, flow rate, reuse volume, storage, any treatment, and total volume in detail; (c) describe the capacity and qualities of tanks and any lined reserve pit to be used for capture and storage of flowback, the expected flowback rate and amount, and the frequency that the storage tanks will be emptied, and (d) describe your plan for testing flowback water. If any part of the well or well site is in an area identified by the U.S. Geological Service as having a 2% or greater probability of exceedance in 50 years of peak ground acceleration of 0.4 standard gravity or more, identify measures you will take to protect the components in this plan against earthquakes of M4.5 or more.



WOOLSEY OPERATING COMPANY, LLC

125 NORTH MARKET, SUITE 1000, WICHITA, KANSAS 67202-1775

(316) -267-4379 FAX (316) 267-4383

Woolsey Operating Company, LLC

Woodrow #1H-310408-193

White County, Illinois

High Volume Horizontal Hydraulic Fracturing Permit Application

HVHHF-10: Hydraulic Fracturing Fluids and Flow back Plan

The Class II injections wells that are planned to be used for disposal are:

Trueflow #1, Reference #216072, SE SW SW, Sec 6-6S-9E, White County, IL., MIT

Date: 3/27/2015

Rankin #1 SWD, Reference #11947, SE N/2 NE, Sec 31-3S-11E, White County, IL.,

MIT Date; 9/20/2013

The fracturing treatment fluids will be flowed into a flow back tank having a capacity of approximately 500 barrels. This "flow back tank" is a closed tank constructed of steel with a sufficient pressure rating and maintained in a leak-free condition for the express purpose of recovering flow back fluids. It is lined with a material resistant to; corrosion, erosion, swelling, deterioration or other damage as a result of exposure to the flow back fluids, see attached diagram. The tank is inspected routinely for corrosion. This tank will be used to separate any gas or proppant in the flow back fluid and measure the flow back fluid volume. Up to five (5) additional closed storage tanks that meet the requirements set out in 245.825(a) will be connected to the primary flow back tank for temporary storage of the flow back fluid (approx. 3,000 barrels of maximum onsite storage). Flow back fluid is comprised of treatment fluid used in the HVHHF operations being primarily 2-5% KCL (Potassium Chloride) with minor amounts of other treating chemicals listed in the Chemical Disclosure Report. Flow back operations will occur at the wellsite on the drilling pad. The temporary storage tanks will be enclosed by earthen containment berms which will be of sufficient size to contain all of the possible flow back fluid temporary storage volume. The flow from the well will be regulated by an adjustable choke. Anticipated flow rates will be between 10 and 25 barrels per hour. The flow back fluid will be hauled on a 24 hour basis as needed. Multiple water transports will be available and will be undertaken by liquid oilfield waste haulers permitted by the Illinois Department of Natural Resources. Expected haul frequency will depend on the flow rate and the size of the truck available. Bobtail trucks commonly can haul 80 barrels at a time and transports 120 barrels. If, for any reason the fluid cannot be hauled timely or safely, the well will be closed in until the fluid can be hauled. There are no plans to use open pits for capture and store of flow back fluids. The primary

site where the flow back fluid will be disposed of at is the TrueFlo Solutions LLC Trueflo #1 Class II disposal facility located in White County, Illinois. A secondary site is the Haggard Well Service Rankin #1 Class II disposal in White County, Illinois. Flow back fluids will not be disposed into the above referenced disposal wells until an electronic flowmeter is installed and approved by IDNR as stated in Section 245.850(g). There are no plans to reuse or recycle the water. The well will be flowed until there is no proppant being produced. At that time flow back operations will cease and the well turned to production facilities. It is anticipated that between 4,000 and 5,000 barrels of flow back will be recovered.

The wellsite lies outside of the area identified by the U.S. Geological Survey as having a 2% or greater probability of exceedance in 50 years of ground acceleration of 0.4 standard gravity or more.

Steel Tank

Bi-Level Coated

Overview:

21,000 gallon bi-level tanks from Rain for Rent have a standard "V" shaped floor for ease of draining all stored liquids completely through a 4" butterfly valve with Buna seals standard. This tank also has a standard vacuum pressure relief valve.

Features:

Store liquids with confidence with Rain for Rent's 21,000 gallon bi-level tank. Permanently attached axels for maximum maneuverability allow this 21,000 gallon tank to be moved with ease on the jobsite and a safety staircase ensures proper protection for workers on site. Epoxy coating offers chemical resistance and additional cleanliness for sensitive environmental applications.



Specs:

| | |
|--------------------|-------------------|
| Manways | Four 22" hatches |
| Material | Steel, Coated |
| Capacity | 21,000 gallons |
| Dry weight | 26,000 lbs. |
| Footprint (LxWxH): | 516" x 96" x 141" |

Accessories:

- Spillguard
- Suction and discharge piping
- Vapor tight features
- Level gauges
- Steam coils

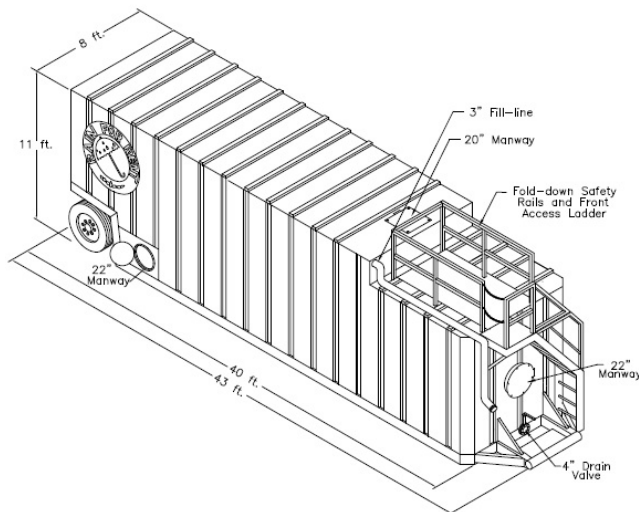

Liquid ingenuity.™

800-742-7246
rainforrent.com

PUMPS • TANKS • FILTRATION • PIPE • SPILLGUARDS

Rain for Rent is a registered trademark of Western Oilfields Supply Company. Features and specifications are subject to change without notice.